

CEILING SYSTEMS

Between us, ideas become reality®

BANDRASTER Suspension Solutions

for Exposed and Concealed Ceilings

Armstrong®

Your ideas become reality®

BANDRASTER Suspension Solutions

for Exposed and Concealed Ceilings

INTRODUCTION

Bandraster is a suspension solution for exposed and concealed ceilings.

Bandraster is currently available in 50mm and 100mm width. It can be used with 24mm grid system.

CUSTOMER BENEFITS:

1. **REFERENCE FOR PARTITIONS:** Bandraster is generally used for drawing references for partitions.
2. **FLEXIBILITY:** Bandraster adds flexibility to the layout. The layout of modular partitions/furniture can be revised without disturbing the ceiling.
3. **ENDLESS POSSIBILITIES:** Bandraster breaks the monotony of steel angles and gives relief to the eye.

APPLICATIONS:

1. IT/ITeS, Voice based Call Centers
2. Modern Corporate Offices.
3. Banks and Insurance.
4. Retail.
5. Educational Institutions.
6. Hospitals

FEATURES

- Standard slots at 300mm centres
- Suitable for both Prelude 24 XL (stab) cross tees
- Sections up to 3.6 m in length
- Comprehensive range of accessories
- Color - Armstrong Global White



Profiles

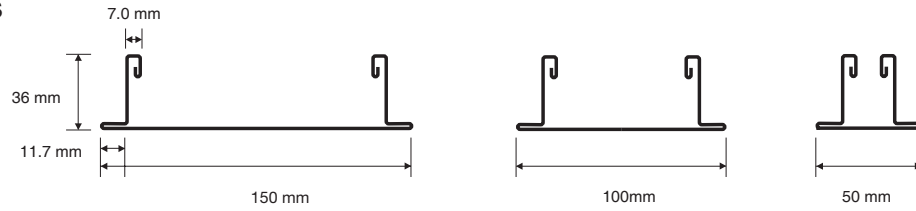

Sections



Item No.	Dimensions (mm)		Content/Carton		Weight/Carton kg	Carton/Pallet
	length	width	pcs	lm		
Slots at 100 mm						
BP 36 1150	3600	150	4	14.40	21.20	20
BP 36 1050 A	3600	100	8	28.80	31.40	16
BP 36 1050 A	3600	50	8	28.80	24.00	28

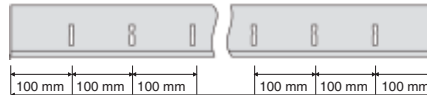

Physical data

- Material**

Galvanised steel

- Surface Finish**

Polyester paint

- Product Family**

Exposed system

- Bandraster/Cross Tee**

Interface

Compatible with either
24 XL cross tees

- Fire Rating**

Armstrong has an extensive range of grid and tile products which can provide fire and/or structural protection. Please contact Technical Sales Team for the relevant grid and tile combination.

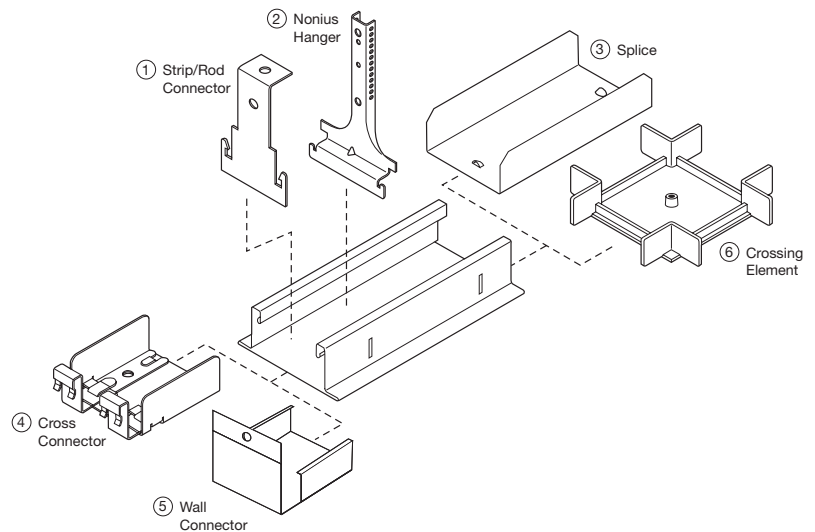

	Width 150			Width 100			Width 50		
	Item Nr	pc/ctn	kg/ctn	Item Nr	pc/ctn	kg/ctn	Item Nr	pc/ctn	kg/ctn
1. Strip/Rod Connector				BP A361001	50	1.80	BP A360501	50	1.20
2. Nonius Hanger	BP A361502	100	15.00	BP A361002	100	11.00	BP A360502	100	5.80
3. Splice	BP A361503	100	19.50	BP A361003A	100	14.00	BP A360503A	100	8.00
4. Cross Connector	BP A361504	50	7.50	BP A361004	50	7.60	BP A360504	50	4.70
5. Wall Connector	BP A361505	50	7.50	BP A361005	50	7.60	BP A360505	50	4.70
6. Crossing Element				BP A361006	32	7.40	BP A360506	48	7.70

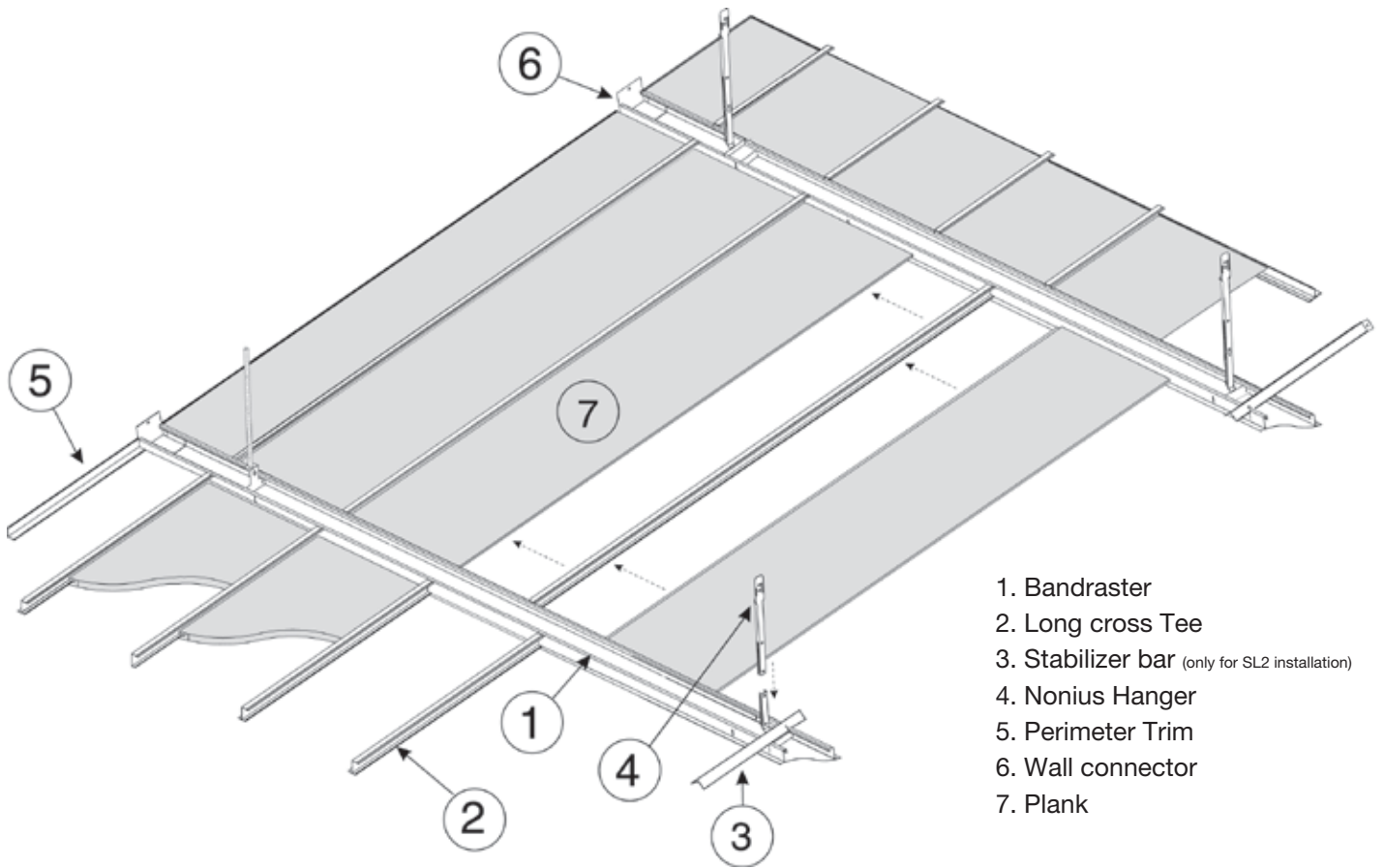

1. Bandrafter
2. Long cross Tee
3. Stabilizer bar (only for SL2 installation)
4. Nonius Hanger
5. Perimeter Trim
6. Wall connector
7. Plank

The Armstrong advantage

1. The widest product range to create vibrant and cheerful interiors.
2. Experienced professionals to help you design customer specific solutions.
3. Assured service through a network of dedicated Dealers and Installation Contractors.
4. Strategically located warehouses ensure timely supply.
5. Consistent and superior quality through global manufacturing standards.

Armstrong World Industries (India) Pvt. Ltd.

B2, G-01, Marathon Innova, Off Ganpatrao Kadam Marg, Lower Parel, Mumbai - 400 013, India.
Tel: 022-3048 0800, Fax: 022-3046 0439 / 2491 3604 | E-mail: helpdeskindia@armstrong.com

Branches:

Ahmedabad: +91-93761 33127	Bengaluru : +91-80-2657 6367	Chandigarh : +91-172 2633 680
Chennai : +91-44-4217 5303	Cochin : +91-93889 39252	Gurgaon : +91-124-4226 381
Hyderabad : +91-40-3200 9868	Indore : +91-93296 82944	Jaipur : +91-93525 69512
Guwahati : +91-96780 69393	Kolkata : +91-33-2401 4755	Lucknow : +91-522-220 1143
Ludhiana : +91-93169 19120	Nagpur : +91-93259 95527	Pune : +91-20-4128 0396/97
Vadodara : +91-93756 76005	Vishakhapatnam : +91-93467 83496	

www.armstrong.co.in

